

Max-E-ProXF[®]

High Performance Pump

by Sta-Rite[®]



New from Sta-Rite[®]:

The most efficient Max-E-Pro[®] pump we've ever made



High performance, high-capacity

Diamond seals made of EPDM rubber are oxidation-resistant for longer life and leak-resistant operation

Dual-compartment motor makes electrical installation easier

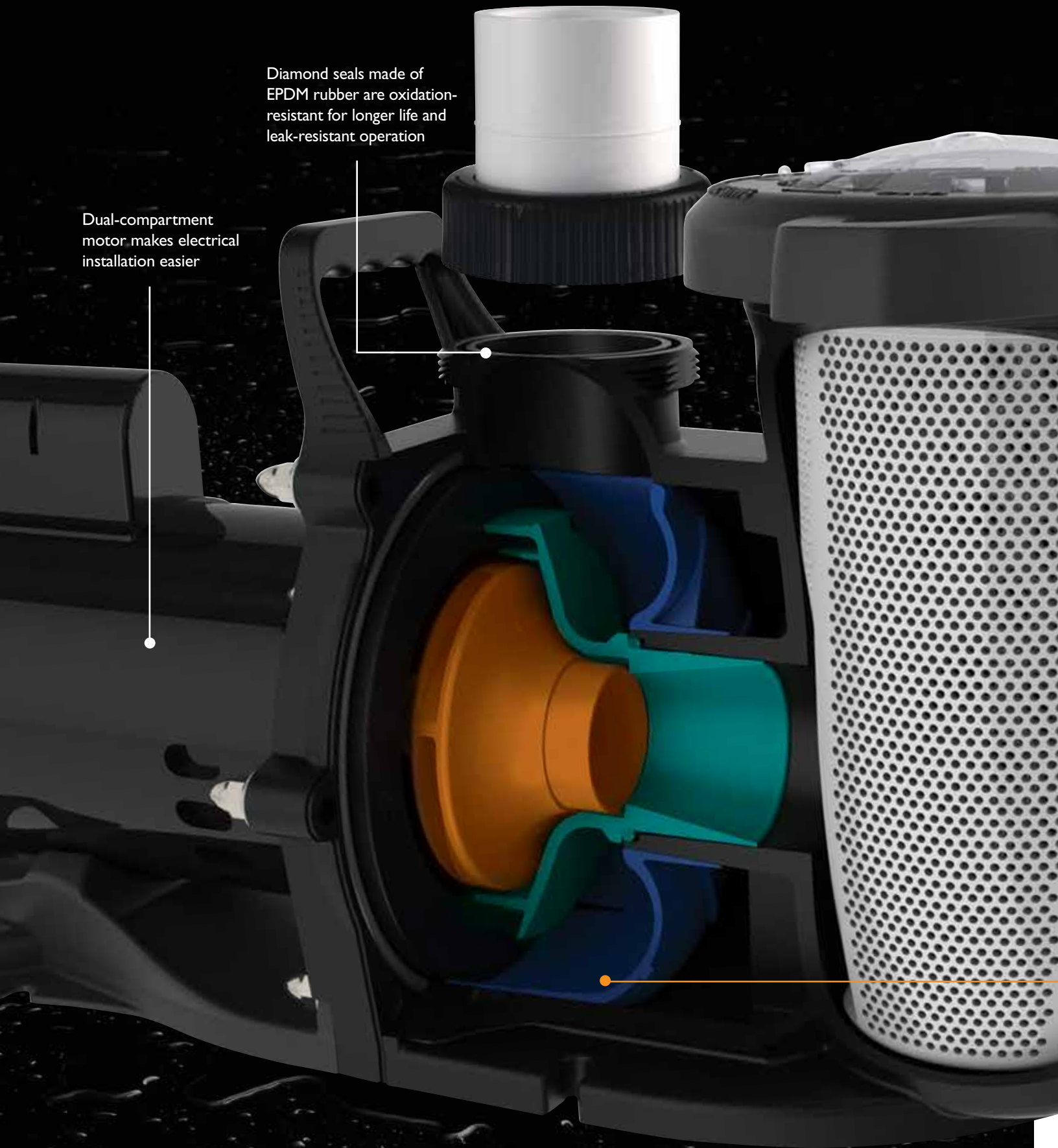

The new Max-E-Pro**XF**® High Performance Pump from Sta-Rite® brings best-in-class energy efficiency, near-silent operation and ultra-dependable performance to high-capacity pool pumps.

Driven by innovation

When we developed this breakthrough pump, we relied on today's computer-aided design and manufacturing (CAD/CAM) plus computational fluid dynamics (CFD) to deliver the best Max-E-Pro® Pump we've ever made. The reward for our hard work is the all-new Max-E-Pro**XF** high performance pump—with energy efficiency that's unsurpassed by any pump in its class.

A higher standard of performance

The new Max-E-Pro**XF** pump is the most efficient, technologically advanced high-capacity pump ever to wear the venerable Sta-Rite badge. With outstanding performance from both a maximum-flow and mean-flow perspective, it's perfectly suited for residential pools with water features such as slides and waterfalls, as well as commercial pools.

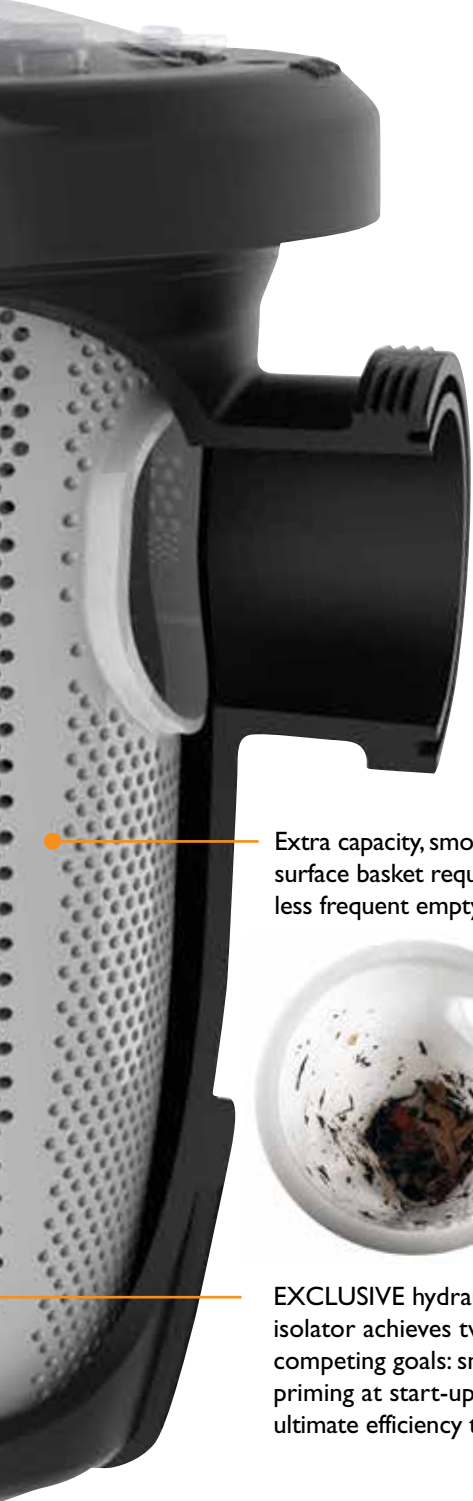

Extra capacity, smooth-surface basket requires less frequent emptying



EXCLUSIVE hydraulic isolator achieves two competing goals: smooth priming at start-up and ultimate efficiency thereafter

Includes free union connectors—connects directly to 2.5" or 3" plumbing with ease



Demand more. Insist on the Max-E-Pro**XF** pump.

The Sta-Rite brand is synonymous with leading-edge technology and has been for over 30 years. Now the new Max-E-Pro**XF** high performance pump—the most powerful and energy-efficient Max-E-Pro pump in Sta-Rite history—continues to raise the bar.

- Free union connectors connect directly to 2.5" or 3" plumbing
- 2, 3 and 5 horsepower models available. Simple replacement for Challenger® High Pressure and High Flow Pumps*; drop-in replacement for all WhisperFlo® High Performance Pump models.
- Clear lid for fast, easy basket inspection.
- Cam and Ramp™ Lid opens with ease, then locks with a simple quarter-turn.
- External port threads and included tool-free unions let you hand-tighten to a perfect fit.
- Easy-carry handle is a back saver at installation time.

*Riser base required for Challenger pump replacements—Part # 400012 available separately.

Max-E-ProXF[®]

High Performance Pump



Cam and Ramp™ Lid enables quick, easy inspection and cleaning

Built-in handle means easier lifting for the installer

New 2.5" or 3" union connectors included

Oversized strainer basket allows more time between cleanings

Performance Curves

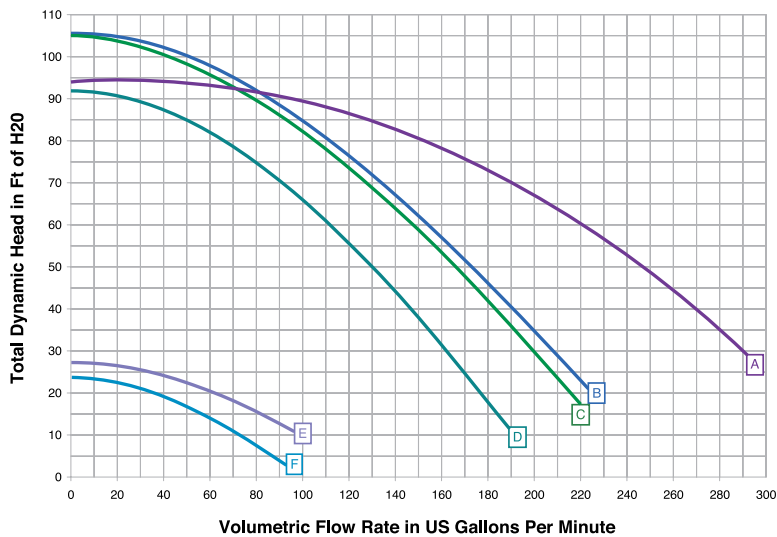

Performance Curve	Model	Description
A	XPE-20	5 HP, High Efficiency
A	XPK-20	5 HP, 3-Phase, TEFC Motor
B	XPE-12	3 HP, High Efficiency
C	XP-12	3 HP, Standard Efficiency
B,E	XPDS-12	3 HP, 2-Speed
B	XPK-12	3 HP, 3-Phase, TEFC Motor
D	XPE-8	2 HP, High Efficiency
D	XP-8	2 HP, Standard Efficiency
D,F	XPDS-8	2 HP, 2-Speed
D	XPE-30	2.5 HP, High Efficiency, Up-rated
D	XP-30	2.5 HP, Standard Efficiency, Up-rated
D,F	XPDS-30	2.5 HP, 2-Speed, Up-rated
D	XPK-8	2 HP, 3-Phase, TEFC Motor

Available from:



Simply Smarter.

www.staritepool.com
Phone: 800-831-7133

pumps / filters / heaters / heat pumps / automation / lighting / cleaners / sanitizers / water features / maintenance products

All Pentair trademarks and logos are owned by Pentair, Inc. Max-E-ProXF[®], Max-E-Pro[®], Sta-Rite[®], Challenger[®], WhisperFlo[®] and Cam and Ramp[™] are trademarks and/or registered trademarks of Pentair Water Pool and Spa, Inc. and/or its affiliated companies in the United States and/or other countries. Because we are continuously improving our products and services, Pentair reserves the right to change specifications without prior notice. Pentair is an equal opportunity employer.